

DATASHEET

HighSpeed HDMI Cable with Eth. HDMI A - DVI-D 18+1, M-M, 10,0m, black



General data

Shielding: foil + braiding
 Conductor: bare copper, Jacket: PVC
 HDMI™ plugs and contacts gold plated and moulded
Cable length up to 20m!
 Full HD - 3D up to 1080p

General data

Number of poles connection 1	19
Number of poles connection 2	19

Cable construction

Connection type connection 2	plug
Connection type connection 1	plug

Kabelaufbau

Type of connector connection 2	DVI-D 18+1
--------------------------------	------------

This datasheet was created automatically on 21-09-2024 . Technical changes reserved.



DATASHEET

HighSpeed HDMI Cable with Eth. HDMI A - DVI-D 18+1, M-M, 10,0m, black

Type of connector connection 1

HDMI (HDMI-A)

Available variants

ArtNr.	Bezeichnung	Colour	Length
K5432.10V2	HighSpeed HDMI Cable with Eth. HDMI A - DVI-D 18+1, M-M, 10,0m, black	black	10.0 m
K5432.20V2	HighSpeed HDMI Cable with Eth. HDMI A - DVI-D 18+1, M-M, 20,0m, black	black	20.0 m

Drawings

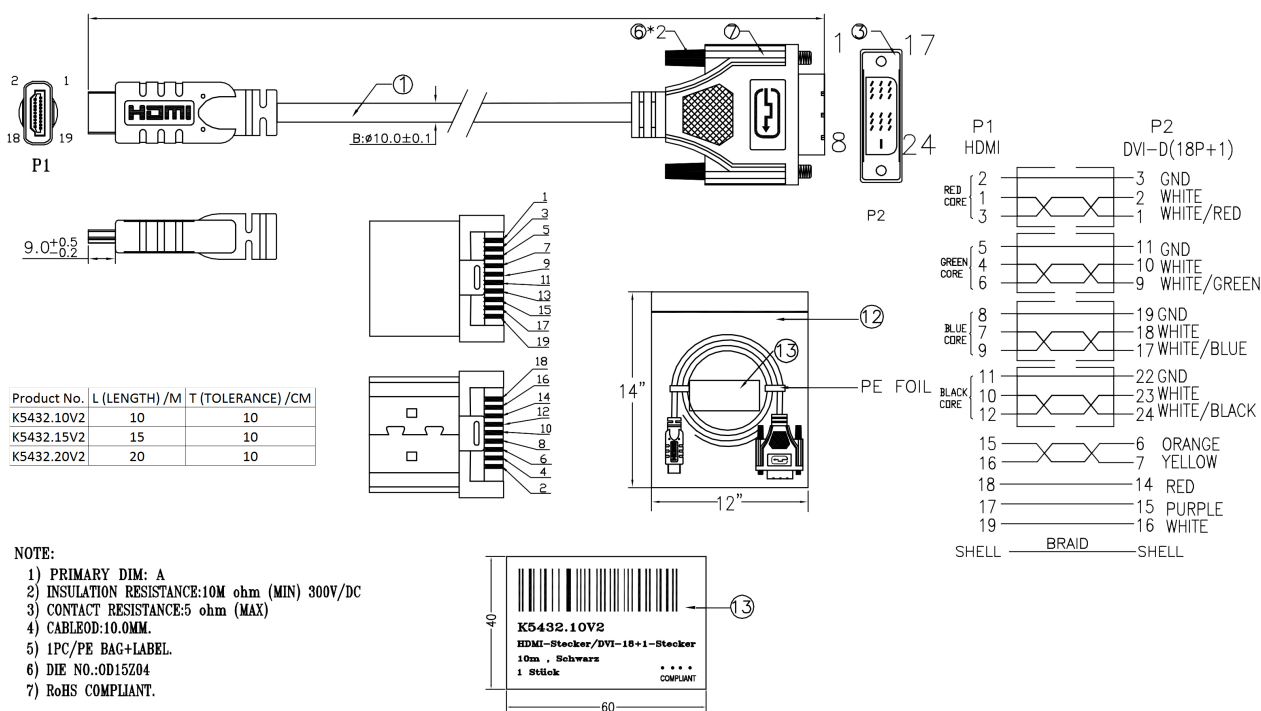

NOTE:

- 1) PRIMARY DIM: A
- 2) INSULATION RESISTANCE: 10M ohm (MIN) 300V/DC
- 3) CONTACT RESISTANCE: 5 ohm (MAX)
- 4) CABLE OD: 10.0MM.
- 5) IPC/PE BAG+LABEL.
- 6) DIE NO.: 0D15Z04
- 7) RoHS COMPLIANT.

3	DVI18P+1 MALE BLACK SOLDER TYPE TERMINAL&SHELL PLATED GOLD W/METAL HOOD OD:10.5MM (RoHS)
2	HDMI A TYPE PLUG TERMINAL&SHELL GOLD SOLDER TYPE W/O METAL (RoHS)
1	UL20276 (24#1Pair+Mylar+Aluminum foil+Drain)*4+24#1Pair+24#3C+Mylar+Aluminum foil+Braid+Drain OD:10.0MM BLACK(1101) 10000MM (RoHS)

This datasheet was created automatically on 21-09-2024 . Technical changes reserved.

