

CONFIGURATION DETAILS OF
UNDIMENSIONED FEATURES
MAY VARY

REVISIONS			
REV	DESCRIPTION	DATE	APPROVED
A0		2022/08/19	

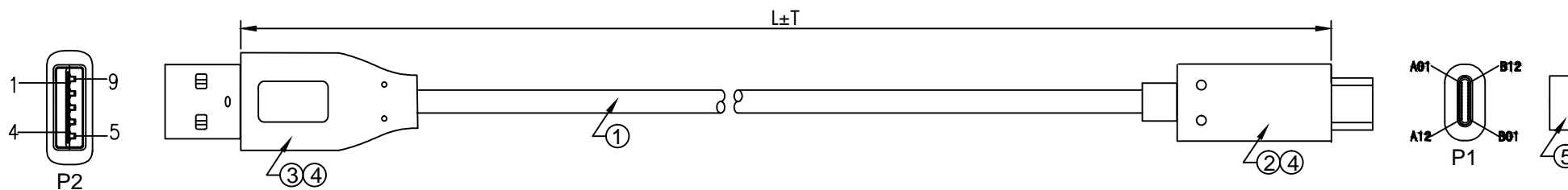

PIN ASSIGNMENT:

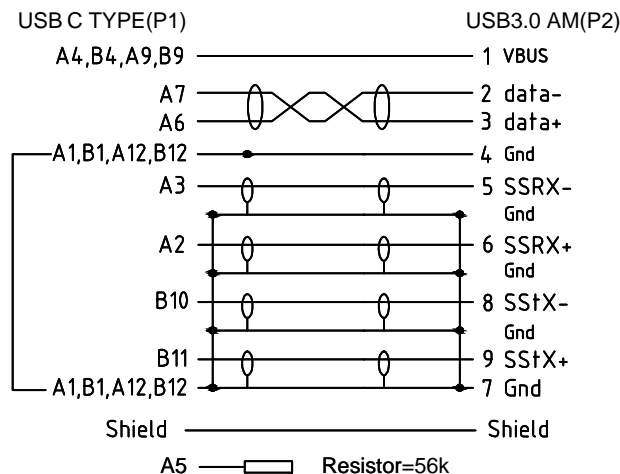

NOTE:

1. Electronic test
 - 1.1 Open/short 100% test
 - 1.2 Compliant with USB3.0 USB2.0 USB1.1
2. Printing: High Speed USB3.0 Cable AWM 2725 80°C 30V VW-1
RoHS2.0(2011/65/EU) AND (2015/863/EU) WITH REACH COMPLIANT

NO.	PART NAME	DESCRIPTION	QUANTITY	REMARKS
⑤	DUST COVER	TRANSPARENT PE	1	
④	OUTER MOLD	PVC/BLACK	2	
③	A MALE	USB TYPE A MALE ,GOLD PLATED PIN,NICKEL PLATED SHELL	1	
②	C MALE	USB TYPE C MALE W,GOLD PLATED PIN,NICKEL PLATED SHELL	1	
①	CABLE	32AWG(1/0.20 TC+E+AM)*2P+32AWG(1/0.20 TC)*1P+8/0.20BC*2C+AM+E BRAID+JACKET,PVC/BLACK,OD4.5±0.2MM	1	

ITEM NO.	LENGTH
S3015	500±20
S3016	1000±20

NAME	STANDARD USB 3.2 Gen1 Cable, A-C, M/M, (5V/3A), black		
ITEM NO.	SEE THE CHART		
	MAPE	TOLERANCE	
		X.	±1.00
DRAW BY	SCALE	MM	
	PAGE	1/1	