



Datenblatt - Fiche technique - Data sheet

**11.09.4355**



ROLINE 3,5mm Verlängerungskabel ST / BU, 5m

ROLINE Rallonge 3,5mm, 5m

ROLINE 3.5mm Extension Cable, M/F, 5 m

# 1. DIMENSION

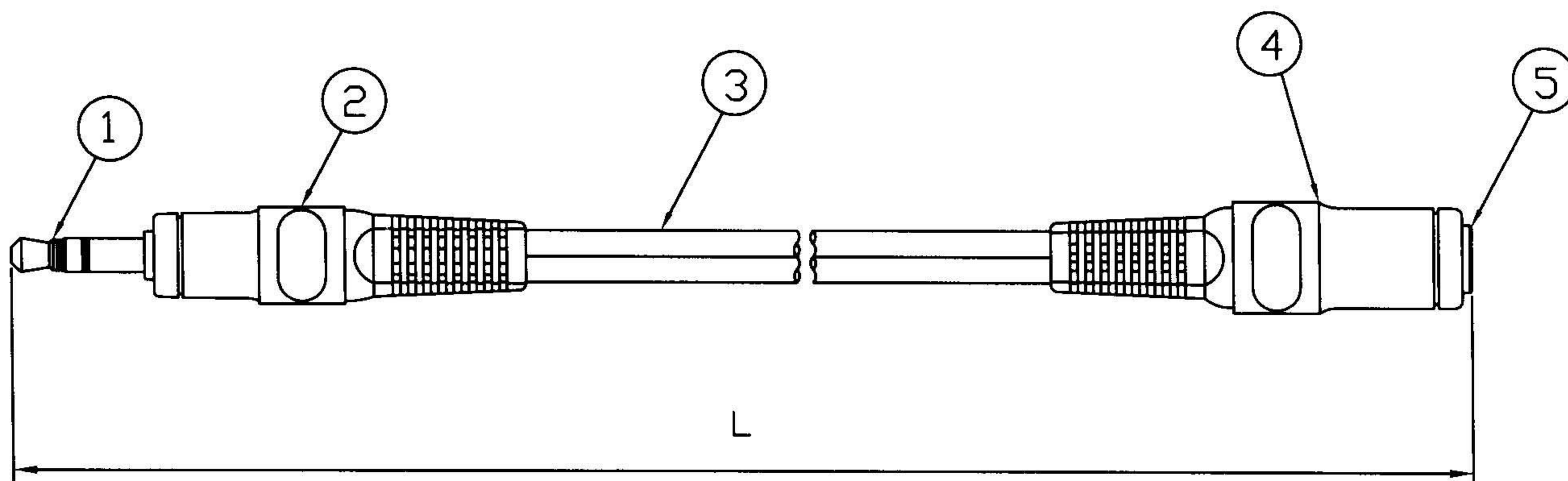

Item no.	L
11.09.4353	3000±100
11.09.4355	5000±150
11.09.4359	10000±200

# 2. PART LISTS

5	∅3.5 ST JACK	BRASS NICKEL PLATED
4	MOLDING(3.5 JK)	PVC BLACK
3	CORD ∅2.7*2.7	PVC BLACK
2	MOLDING(3.5 PL)	PVC BLACK
1	∅3.5 ST PLUG	BRASS NICKEL PLATED
NO	PART NAME	MATERIAL.COLOR

△					表面 FINISHED		Rotronic Co., Ltd.	
△					顏色 COLOR			
△					厚度 THICKNESS			
△					處理 PROCESS			
△					材質 MATERIAL			
△					公差 TOLERANCE			
記號 MARK	修正 REVISION	日期 DATE	擔當 SIGN	承認 APPO	比例 SCALE	單位 UNIT	件 號 名 稱 圖 號	PART NO 11.09.4353,55,59
承 認	檢 圖	設 計	製 圖	製 圖	92.4.29	mm	AUDIO CONNECTION CORD	DESCRIPTION.
許文勳	許文勳	許文勳	許文勳	何俊昇			DRAWN NO. SP-0576	SHEET 1/6

### 3. 3.5 STEREO PLUG DIMENSION

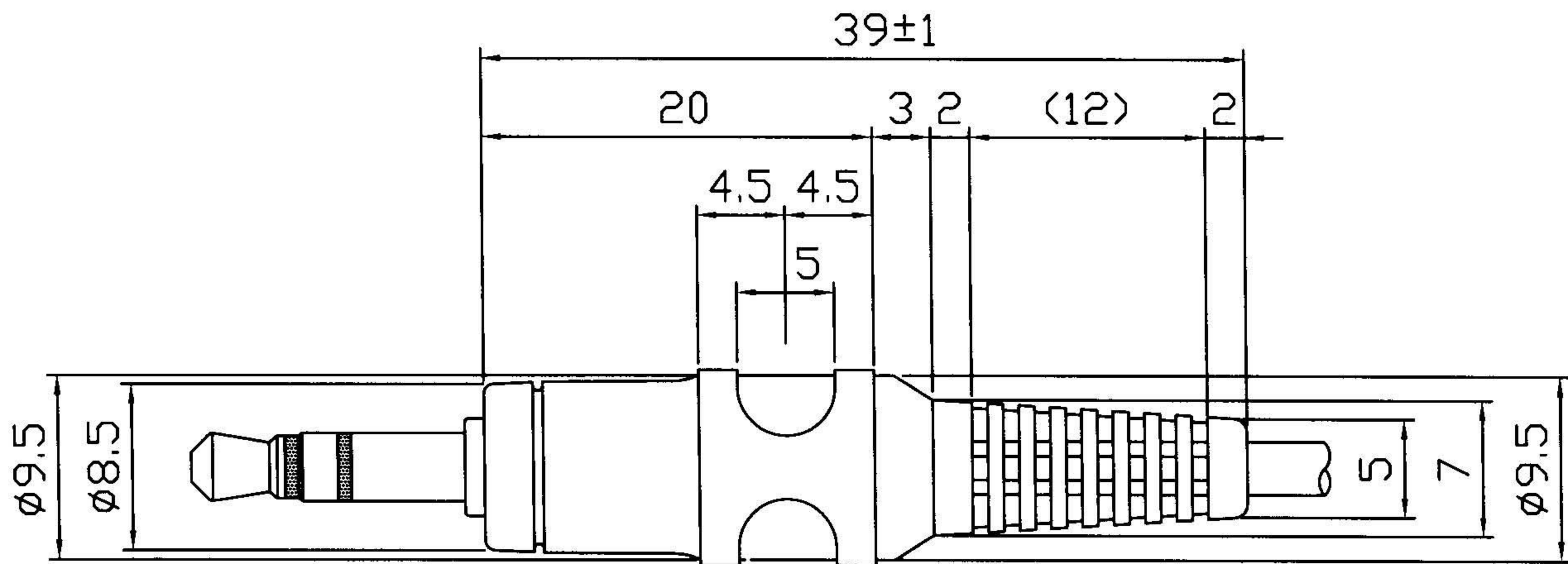
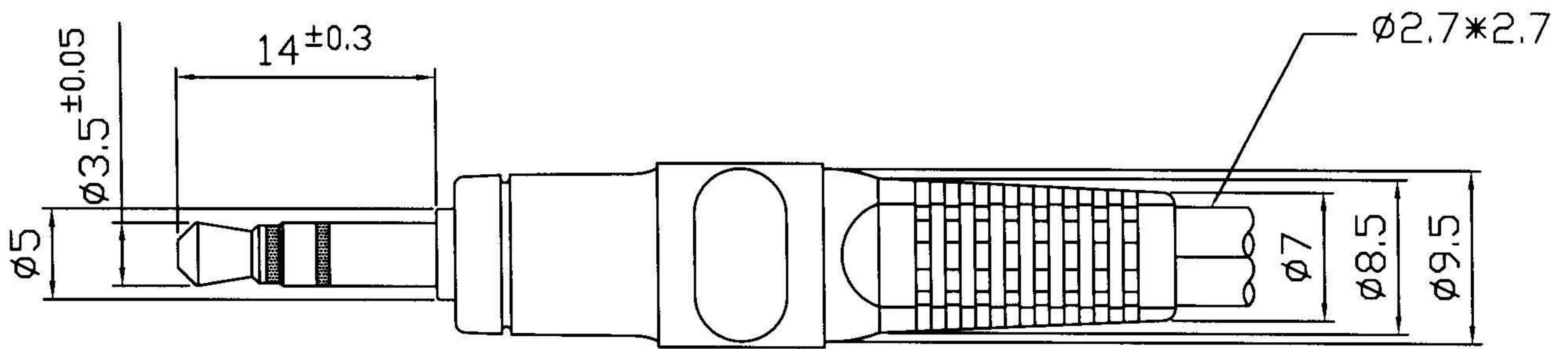

STS-2

$L \leq 4$	$\pm 0.1$
$4 < L \leq 16$	$\pm 0.2$
$16 < L \leq 63$	$\pm 0.3$
$63 < L \leq 250$	$\pm 0.4$
$250 < L$	$\pm 0.6$

名稱	DESCRIPTION. <b>AUDIO CONNECTING CORD</b>	圖號	DRAWN NO. <b>SP-0576</b>	SHEET <b>2</b>
----	--	----	-----------------------------	-------------------

### 3-1. 3.5 STEREO JACK DIMENSION

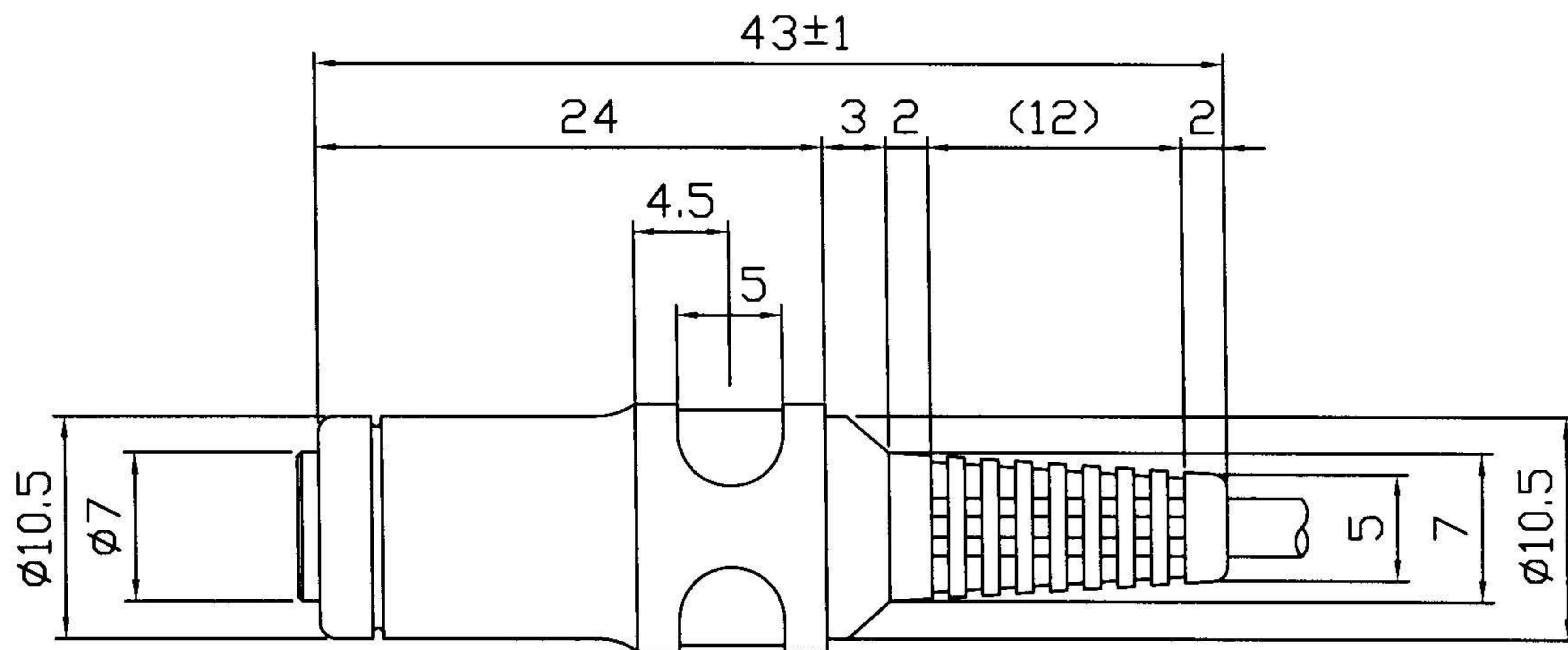
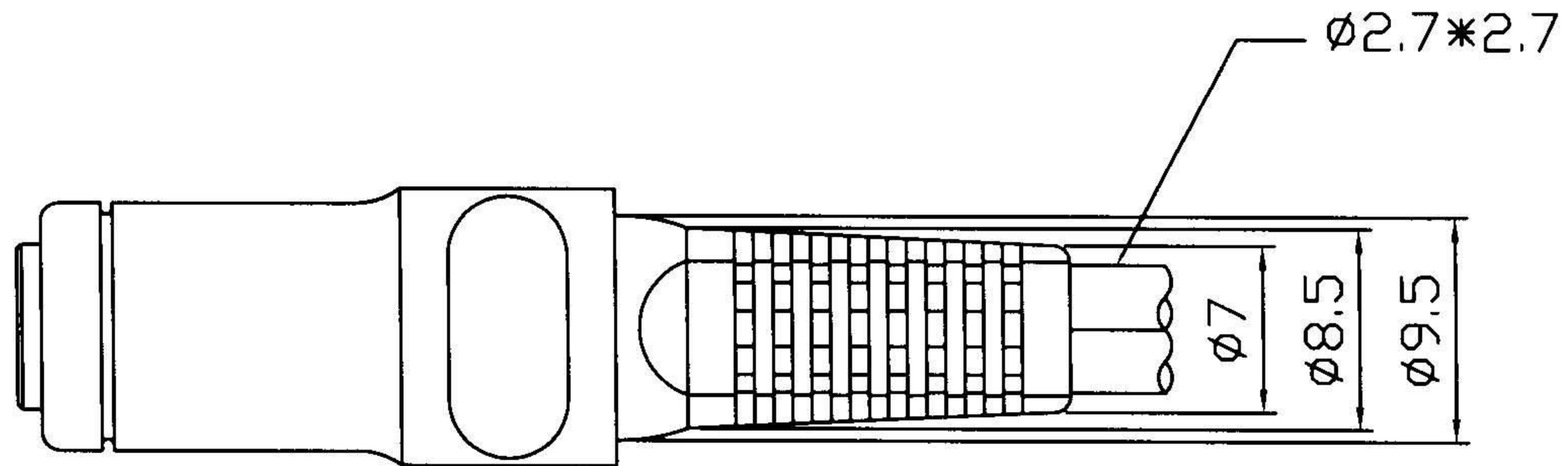

STS-2

L ≤ 4	±0.1
4 < L ≤ 16	±0.2
16 < L ≤ 63	±0.3
63 < L ≤ 250	±0.4
250 < L	±0.6

名稱	DESCRIPTION. <b>AUDIO CONNECTING CORD</b>	圖號	DRAWN NO. <b>SP-0576</b>	SHEET <b>3</b>
----	--	----	-----------------------------	-------------------

# 4 CORD SPEC

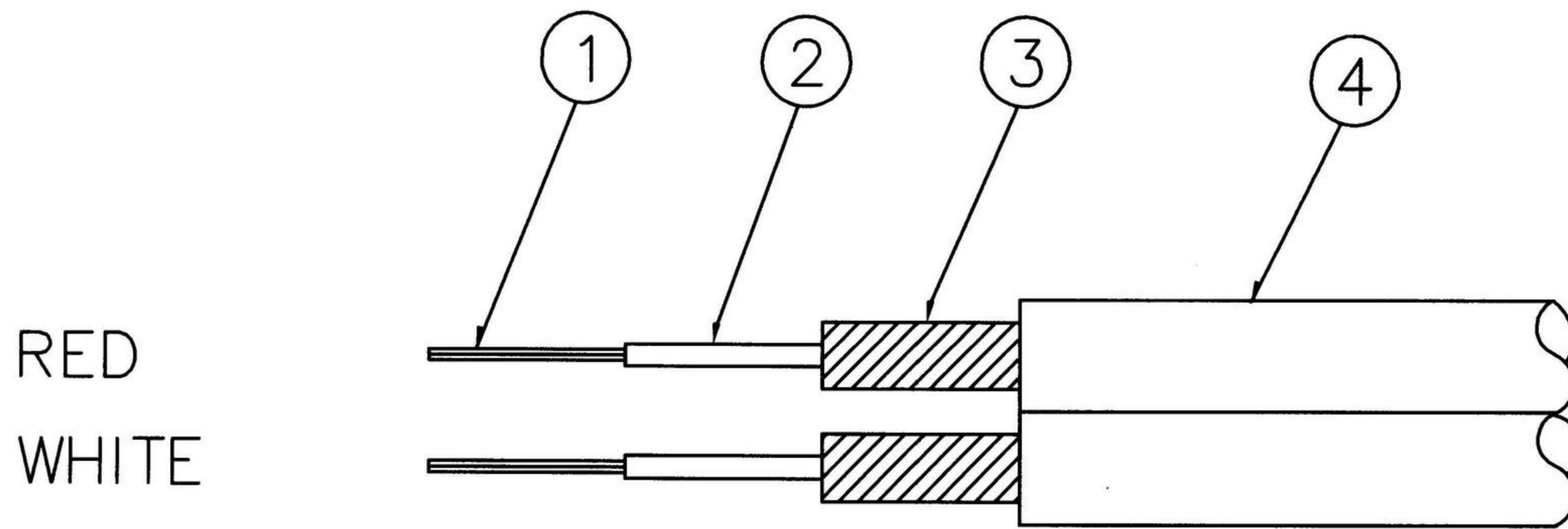

	DESCRIPTION	MATERIAL	SPECIFICATION
①	CONDUCTOR	OFC COPPER	0.12*10*2C
②	CORE DIA.	PE(R)(W)	$\varphi 1.3^{\pm 0.1}$ *2C
③	SHIELD WIRE	OFC COPPER	0.12*28*2C
④	JACKET	PVC	$\varphi 2.7^{\pm 0.1}$ * $2.7^{\pm 0.1}$ mm
	NON MIGRATION	BLACK	FOR ABS PLATE

# 5. CHARACTERISTICS

## STANDARD ATMOSPHERIC CONDITIONS

UNLESS OTHERWISE SPECIFIED, THE STANDARD RANGE OF ATMOSPHERIC CONDITIONS FOR MAKING MEASUREMENTS AND TESTS ARE AS FOLLOWS:

AMBIENT TEMPERATURE : 5°C TO 35°C  
 RELATIVE HUMIDITY : 45% TO 85%  
 AIR PRESSURE : 86KPa TO 106KPa

IF THERE IS ANY DOUBT ABOUT THE RESULTS. MEASUREMENTS SHALL BE MADE WITHIN THE FOLLOWING LIMITS:

AMBIENT TEMPERATURE : 20±2°C  
 RELATIVE HUMIDITY : 60% TO 70%  
 AIR PRESSURE : 86KPa TO 106KPa

NO	ITEMS	CONDITIONS	SPECIFICATIONS
1	APPEARANCE		NO DEFECTS SUCH AS CRACKS, SCRATCHES OR BLEMISHES.
2	INSERTION FORCE WITHDRAWAL FORCE	MEASUREMENT SHALL BE MADE AFTER INSERTING INTO ITS MATING PLUG OR SOCKET 3 TIMES.  3.5 PLUG / JACK	4.9N(0.5Kgf) ~ 19.6N(2.0Kgf)
3	TENSILE STRENGTH	BETWEEN CABLE & CONNECTOR 29.4N(3.0KGF) , 1 MINUTE	NO DAMAGE SUCH AS DISPLACEMENT OR INSULATION DAMAGE,ETC
4	FLEXING TEST	300G, ± 60° ,1000TURNS 15~20/PER MIN TURNS	NO DAMAGE SUCH AS DISPLACEMENT OR INSULATION DAMAGE,ETC
5	INSULATION RESISTANCE	DC 250V 1 MINUTE BETWEEN CONDUCTORS	100 MΩ OR MORE
6	DIELECTRIC STRENGTH	AC 250V SHALL BE APPLIED FOR 1 MINUTE WITH TRIP CURRENT 2 mA BETWEEN CONDUCTORS	WITHOUT DAMAGE SUCH AS ELECTRIC BREAKDOWN
7	ABS NON-MIGRATION	TEMPERATURE : 54 ± 1 °C TIME : 24± 1H WEIGHT : 500 ±25 G	WHEN VISUALLY INSPECTED. ANY STAINING OF THE AREA OF THE ABS THAT WAS IN CONTACT WITH THE TEST PIECES SHALL HARDLY BE RECOGNIZED

名 稱	DESCRIPTION.  <b>AUDIO CONNECTING CORD</b>	圖 號	DRAWN NO.  <b>SP-0576</b>	SHEET  <b>5</b>
--------	--	--------	---------------------------------	-----------------------

# 6. PACKAGE

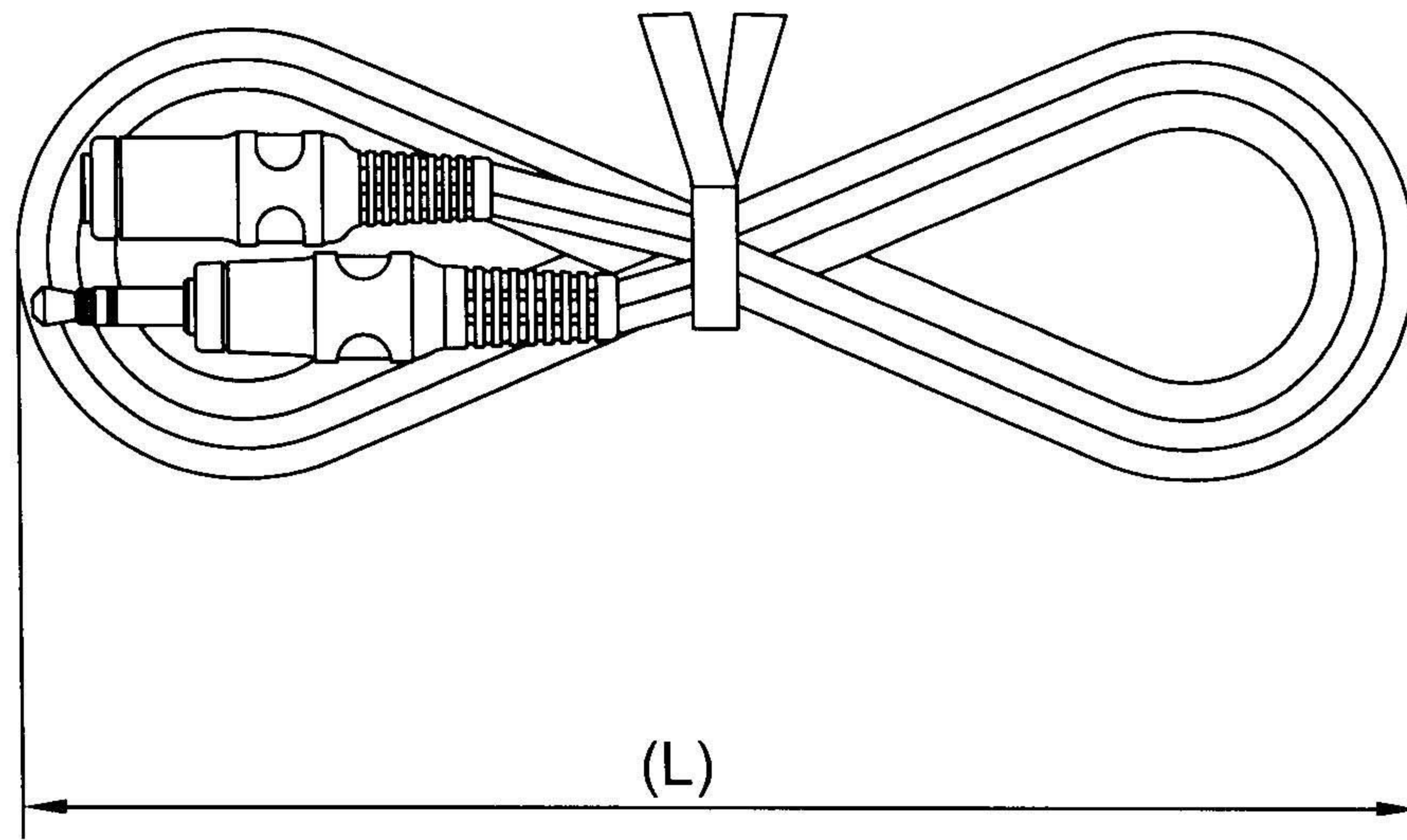

Item no.	(L)
11.09.4353	125
11.09.4355	160
11.09.4359	160

名稱	DESCRIPTION. <b>AUDIO CONNECTING CORD</b>	圖號	DRAWN NO. <b>SP-0576</b>	SHEET <b>6</b>
----	--	----	-----------------------------	-------------------