

NOTES:

TESTING: 100% OPEN AND SHORT AND MISWIRE TEST
 CONDUCTION RESISTANCE: 5 OHM MAX
 INSULATION RESISTANCE: 10 OHM MAX
 WITHSTAND VOLTAGE: 300V
 CAPACITIVE REACTANCE: 42PF/M
 TRANSMISSION DELAY: 4.23NS/M

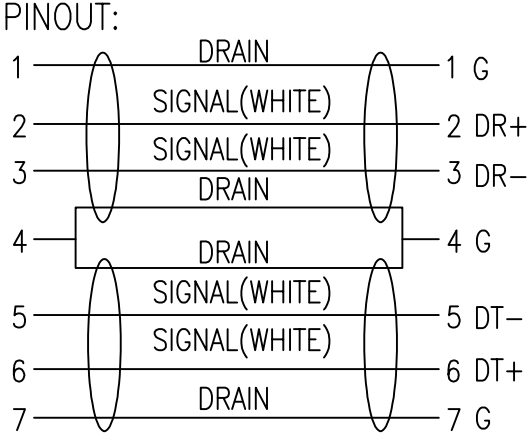

NAME	VALUE Internal SATA 3.0 Gbit/s Cable, angled, 0.5m
Item No.	11.99.1556

④	SATA BLACK 26# 8C/ST (4/0.404TC+4/0.32TC) OD=7.6*2.2MM
③	OUTTER MOLDING: 45P PVC BLACK
②	INNER MOLDING: PE
①	SATA 7P PIN NICKEL

SECOMP	MAPE	TOLERANCE	
		X.	±1.00
		X.X	±0.50
	DRAW BY	SCALE	MM
	PAGE	1/1	